



INSTRUCTIONS

#82239 Sportbike EFI Direct Port Nitrous System

Thank you for choosing ZEX™ products; we are proud to be your manufacturer of choice. Please read this instruction sheet carefully before beginning installation and take a moment to review the included limited warranty information.

Major Components List

| Description | Qty. | Description | Qty. |
|-------------------------------|------|---------------------------------------|-------|
| Nitrous Solenoid | 1 | .043 N20/ Fuel Jet | 1 |
| Fuel Solenoid | 1 | .038 N20/ Fuel Jet | 1 |
| 1/4NPT to -4AN Filter Fitting | 2 | .033 N20/ Fuel Jet | 1 |
| 2' Hose, -4AN, purple | 2 | .032 N20/ Fuel Jet | 1 |
| 2' Hose, -3AN, .106 Insert | 1 | .028 N20/ Fuel Jet | 1 |
| 2' Hose, -3AN, .086 Insert | 1 | .026 N20/ Fuel Jet | 4 |
| 7.5" Hose, -3AN, .086 Insert | 4 | .024 N20/ Fuel Jet | 1 |
| 7.5" Hose, -3AN, .040 Insert | 4 | .021 N20/ Fuel Jet | 4 |
| Direct Port Nitrous Nozzle | 4 | .019 N20/ Fuel Jet | 5 |
| Distribution Block A | 1 | TPS Activation Box | 1 |
| Distribution Block B | 1 | Arming Switch | 1 |
| 1/8NPT to 3/16 Comp. Fitting | 2 | Aircraft Switch Cover | 1 |
| -4AN to 1/8 NPT Fitting | 2 | 30 Amp Fuse Holder | 1 |
| -3AN to 1/8 NPT Fitting | 2 | 30 Amp Fuse | 1 |
| 2lb. Nitrous Bottle w/Valve | 1 | 20 Amp Mini Relay | 1 |
| Bottle Bracket | 1 | Red 18 GA. Wire | 4 ft. |
| Solenoid Bracket | 2 | White 18 GA. Wire | 4 ft. |
| .105 N20/Fuel Jet | 1 | 5/16-18 X 1" Bolt for Bottle Brackets | 2 |
| .076 N20/ Fuel Jet | 1 | 5/16 - 18 Nut for Bottle Brackets | 2 |
| .067 N20/ Fuel Jet | 1 | 5/16 Flat Washer | 2 |
| .057 N20/ Fuel Jet | 1 | 8-32 Socket Head Cap Screw | 2 |
| .056 N20/ Fuel Jet | 1 | #14 x 3/4 Sheet-metal Screw | 4 |
| .054 N20/ Fuel Jet | 4 | 10-32 Button Head Cap Screw | 4 |
| .046 N20/ Fuel Jet | 1 | 1/8-27 NPT Tap | 1 |

Why our nitrous system is better:

- A complete sportbike specific EFI direct port nitrous system. Everything is included in this kit for an easy, plug and play installation.
- Adjustable from 50-200 horsepower. Safe enough for totally stock engines, but powerful enough for serious performance use.
- System is activated at wide open throttle with advanced electronics that monitor your throttle position sensor (TPS); easy and safe activation.
- Unique nozzle design has "Active Fuel Control™" built in. This feature monitors bottle pressure and when the nitrous system is engaged, it adds or subtracts enrichment fuel so the engine never runs too rich or too lean.

**NITROUS
HELP™**
888.817.1008

ZEX™
3418 Democrat Rd.
Memphis, TN 38118
Phone: 1-888-817-1008 Fax: (901) 375-3430
www.zex.com

Part #ZEX193
Revised 9/5/07

Read This Pre-installation Guide Before Installing Kit !!!!!!!

How the ZEX™ nitrous system works: The ZEX part #82239 nitrous system begins with a connection to a supply cylinder containing pressurized liquid nitrous oxide and a connection to the engine's fuel system. These connections go to the system's nitrous and fuel solenoids, respectively. These solenoids are normally closed, but are opened when the nitrous system is armed, and the electronic TPS throttle switch is activated by going to wide-open throttle. Once these solenoids open, the nitrous and fuel are delivered to the nozzles, via braided stainless steel delivery lines. The amount of nitrous and fuel that is injected is adjustable by means of metering jets installed in the distribution blocks and nozzles. These metering jets allow for easy changes in horsepower settings.

Work safely. Always wear eye protection and gloves when working with lines or hoses that contain pressurized nitrous oxide or fuel. Never transport nitrous cylinders loose in a trunk or the back of a pick-up truck and especially NOT within a vehicle's interior whether the cylinder is full OR empty. Always disconnect the GROUND side of the battery when working on any electrical components.

Nitrous oxide won't fix problems you already have. Before you install your nitrous system, be sure your engine is in good mechanical condition. Intermittent wiring problems, etc., can lead to erratic system performance and possible engine damage.

Never defeat operation of the safety relief disc in the nitrous cylinder's valve. It's required by law and is there for your safety. Never drill, machine, weld, deform, scratch, drop, or modify a nitrous oxide tank in ANY way whatsoever!

Never overfill nitrous cylinders. That little bit extra will put you and others at risk of injury. More often than not, when the cylinder warms up, the pressure goes above the limit of the safety relief disc and you lose all the nitrous you just paid for.

All the power comes from the fuel, not the nitrous. Nitrous oxide is simply a tool that allows you to adjust how much and how quickly the engine burns the fuel. If the fuel isn't there, the power won't be either.

Avoid detonation at all times. Nitrous enhanced detonation is much more damaging than detonation that occurs when naturally-aspirated due to the increased amount of fuel available for releasing energy and the fact that more oxygen is present.

When system is activated, if something doesn't feel or sound right, BACK OFF. If you hear any detonation or feel anything unusual, get off the throttle. It's a lot easier to check everything over than it is to just try to ride through it and damage expensive parts. Don't activate or have the system activated when you hit the stock rev limiter. The stock rev limiter is a fuel cutoff. If you cut fuel while you're injecting nitrous, you're instantly very lean. This momentary lean condition has the potential of causing engine damage.

Spark plugs and nitrous performance: The factory spark plugs are not suitable for use with nitrous. They are designed with a hotter heat range and can cause a detonation condition after just a few seconds of nitrous use. The solution to the problem is to install spark plugs that have a colder heat range and proper ground strap design for nitrous use.

Engine modifications: If major engine modifications have been performed, a fuel pump upgrade will be required for safe nitrous system operation. Major engine modifications would include turbochargers, aftermarket cylinder heads, head porting, camshafts, etc. Failure to upgrade the fuel system when using nitrous in these highly modified applications may cause serious lean conditions that can result in severe engine damage.

Do not use Teflon sealing tape on any fittings in a ZEX™ nitrous system. It is easy for Teflon tape to get pulled into the system, causing blockages that can ultimately lead to incorrect nitrous system performance and potentially, engine damage. Only use liquid thread sealer for all NPT type fittings. Do not use any thread sealing compound on AN style threads.

Do not attempt to start your engine if nitrous has been accidentally injected into the engine while it was not running. If this occurs, disable all of the ignition coils by unplugging the leads going to them. Hold the throttle at wide-open, pull the clutch in, and with the throttle wide open, engage the starter and turn over the engine for several seconds to clear the nitrous from the engine. Failure to do this before attempting to restart the engine can lead to a dangerous intake system backfire.

Do not engage your nitrous system below 3500 rpm. This ensures that you will not have excessive cylinder pressures that could cause engine damage. The ZEX™ Traction Control Window Switch (**Part #82085**) is ideal for controlling the rpm range that your nitrous system operates in.

When finished using your nitrous system, close the nitrous bottle valve and relieve the line pressure. This eliminates the possibility that nitrous could inadvertently accumulate in the intake runners while the nitrous system is not being used.

Do not run excessive bottle pressures. Excessive bottle pressures, over 1100psi, are dangerous to your engine. Your ZEX™ nitrous system is calibrated and optimized to operate from 900-1000psi. Exceeding this will not improve performance. Over 1100psi also runs the danger of locking the nitrous solenoid closed due to excessive pressure working against the valve's plunger. If this happens, you must cool the nitrous bottle down to lower the pressure. This will allow the valve to operate properly again.

Start with the lowest horsepower setting and work your way up. This ensures if you have any tuning issues to work out, they will get sorted out with a smaller shot of nitrous that will be less likely to damage your engine. Once you have the Bike working well on the smaller shot, you can then safely start to step up your nitrous kit horsepower.

Make sure your bike has an adequate fuel supply. Nitrous systems put a large demand on your bike's fuel system. Make sure you have a large enough fuel pump to handle the demands of your engine, as well as the nitrous system.

How to adjust power levels: The ZEX™ nitrous system is designed for multiple power levels. Metering jets installed in the nitrous nozzle and distribution blocks control these power levels. To change the power output, all you need to do is install the appropriate set of jets. The correct combination of jets is listed on the tune-up sheet on the back of this instruction manual.

Engine computer modifications: Do not use the nitrous system if a non-nitrous custom tune has been programmed into your engine's computer. Custom computer tunes generally advance the ignition timing to optimize non-nitrous horsepower. If nitrous is injected while these non-nitrous tunes are loaded into your engine's computer, detonation will occur and this can lead to severe engine damage. It is important to only use computer tunes that have been specifically programmed for nitrous use. Specific tunes for nitrous should have the ignition timing reduced, per the tune-up chart at the end of this instruction manual. It is generally recommended that you retard the ignition timing around 2 degrees for every 50 hp worth of nitrous used, based on an optimized ignition curve for your engine.

Installation Instructions

1. **Decide where to put everything.** Before you start to install the various components of this kit, you'll have to find the best locations of each component by trial fitment and careful measurement. First, decide where you want to mount the nitrous and fuel solenoids. Remember, the stainless steel braided lines that connect the solenoids to the distribution blocks are 24 inches long. Observe and mark the locations on the intake runners where you would like to put the nitrous nozzles. The arming switch should be installed in a position convenient to the rider, but not in an area where it could be accidentally armed. Next, decide where and how you'll mount the nitrous supply bottle. The bottle comes without a siphon tube installed, so in that configuration, it needs to be mounted upside down. If you want the bottle mounted vertically, you will have to unscrew the bottle valve and install the included compression fitting and siphon tube. Finally, have a reputable performance shop fill your nitrous bottle before you begin. Do not overfill the nitrous bottle.
2. **Mount nitrous supply bottle.** There are two different positions you can mount the bottle in. The first position is to mount the bottle "upside-down". This is the correct position for the bottle as it comes in the kit, as the bottle does not have a siphon tube installed from the factory. If you would like to install the bottle in the "vertical" position, you will have to remove the bottle valve and install the compression fitting and siphon tube that is included in the kit. Remember to re-torque the bottle valve to 60 ft.lbs. Remember to always mount the bottle so that as your bike accelerates, the liquid flows towards the pick-up.
3. **Run the nitrous delivery line.** Attach the 2 ft. long, -4AN delivery line to the bottle and route it through the bike to where the nitrous solenoid will be mounted. We have included cable ties in the kit to secure it in place.
4. **Mount nitrous and fuel solenoids.** Install the -4AN filter fittings into the inlets and the -3AN fittings into the outlets of both the nitrous and fuel solenoids. Keeping in mind the length restrictions of the nitrous/fuel feed lines, mount the solenoids and connect the -4AN nitrous feed line to the nitrous solenoid inlet.
5. **Install nitrous nozzles.**
 - A. Remove the airbox and throttle bodies to get access to the intake runners.
 - B. Using an 11/32 dia. drill bit, drill each intake runner where you would like to position the nitrous nozzles. Remember to take precautions to eliminate any chances of drill shavings falling into the engine's intake ports.
 - C. Use the 1/8 NPT tap that is included with the kit to tap the holes you have just drilled in the intake runners. Take special care to not tap the holes too deep. It is recommended to tap a few turns at a time, back the tap out, clean out the shavings, and test fit the nozzle to the NPT threaded hole. When all four holes have been tapped, thoroughly clean and blow out all shavings from the inside of the intake runners.
 - D. Using a liquid thread locking compound on the threads, install the nozzles in the threaded holes. Make sure the nozzles are pointing in the correct direction. The outlets should face toward the cylinder head.
 - E. Assemble the distribution blocks and lines (Fig. 1).

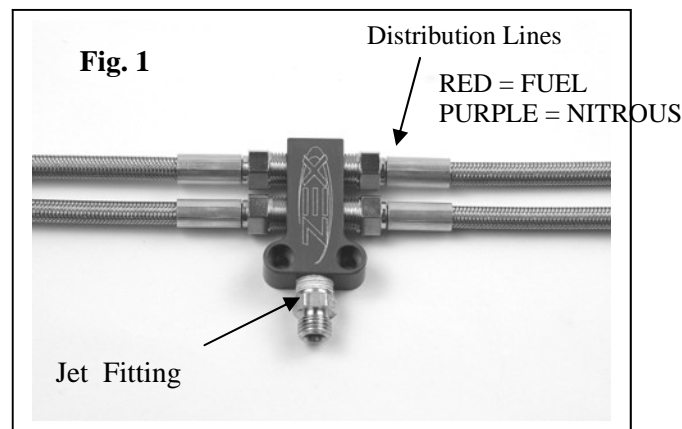

- F. Install the jets for both fuel and nitrous in the nitrous nozzles (fig. 2).
- G. Attach the fuel and nitrous distribution lines to the nitrous nozzles. Be sure to use a 3/8in. wrench to hold the jet fitting as you are tightening the 7/16 swivel nut on the distribution lines.
- H. Insert the correct jets in the fuel and nitrous jet holders in the distribution blocks (fig. 2).

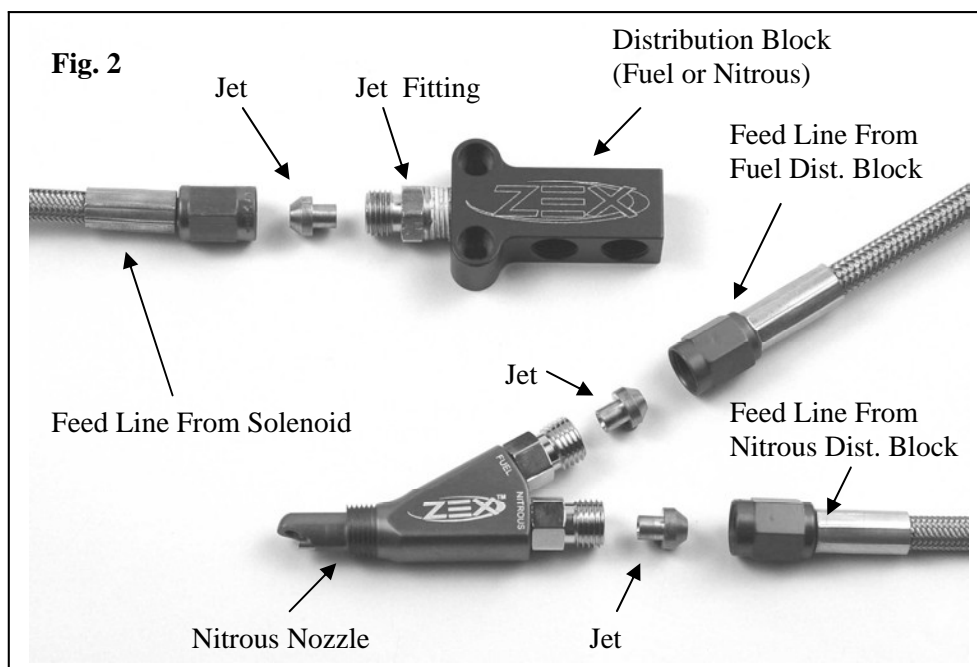

- I. Attach the 24 in. -3 AN hose, with the red ends, to the fuel solenoid outlet. Attach the other end of this line to the fuel distribution block's jet fitting. Attach the 24 in. -3 AN hose, with the purple ends, to the nitrous solenoid outlet. Attach the other end of this line to the nitrous distribution block's jet fitting. Once all the fittings have been tightened-up, take the two 8-32 socket head cap screws and screw the distribution blocks together.
6. **Wire it.** Once you have mounted the components, you are ready to wire the nitrous system. Refer to the wiring diagram for the correct connections (Fig. 3). Remember to combine together both blue wires on the electronic TPS activation switch for proper system activation.

- 7. Program activation switch.** Now that you have completed the wiring of your nitrous system, the next step is to program the Activation Switch. To program the Activation Switch, turn the motorcycle's ignition on, but do not start the engine. Turn the nitrous arming switch to the "ON" position. Go to the Electronic Throttle Position Switch (ETPS) and locate the push-button switch. Depress, then release, the push-button switch. Observe the ETPS's Operation Light. At this point, it should be RED. This RED light informs you that the ETPS's Activation Switch is in learn mode. Return to the throttle and open it all the way, holding it there for ten seconds. Release the throttle and go back to the ETPS and observe the Operation Light. At this point, the light should be flashing continuously from RED to GREEN to OFF. This is the ETPS's way of telling you that it has successfully learned the voltage curve of your engine's throttle position sensor. Go back to the system's arming switch and turn it off, then turn it back on. Go back to the ETPS and observe the Operation Light. It should be solid GREEN at this point. This informs you that the system is armed and ready to activate at wide-open throttle. Return to the throttle and open it all the way, several times. You should hear the solenoid click each time you reach wide-open throttle. At this point, your Activation Switch is fully programmed and ready for use. If you ever transfer your nitrous system to another motorcycle, perform this same procedure to "relearn" the ETPS Activation Switch.
- 8. Connect fuel source.**

 - A.** Locate a source of fuel from the bike's fuel system that will provide at least 40psi at wide-open-throttle. Tee into this fuel source and connect the 2 ft. long -4AN hose to it. If needed, a -4AN to 1/8NPT fitting is supplied in the kit.
 - B.** Attach the 2ft., -4AN fuel delivery line, from the fuel source, to the fuel solenoid inlet.
- 9. Adjust ignition timing.**

 - A.** It is important when using nitrous that you retard your ignition timing for the level of power you are jetting to. There are several commonly available performance programmers on the market today that will allow you to adjust this on most popular bikes. Stock timing can be used for 50hp or less nitrous jetting. If timing has already been optimized for maximum power with one of these programmers, an additional 2 degrees of ignition timing should be removed per 50hp worth of nitrous used. **If the correct ignition timing is not used, severe engine damage may occur from detonation.**
- 10. Inspect.**

 - A.** Perform a final inspection of all plumbing and electrical connections to ensure that they are correct.
 - B.** Open the nitrous bottle valve. Listen carefully for any leaks as your valve is opened. Leaks in the nitrous supply line will be obvious because they will be covered in frost.
 - C.** If everything checks out, close the nitrous bottle and relieve the line pressure.
- 11. Check fuel quality.** The last thing to do before enjoying your new nitrous system is to ensure you are using the correct fuel for your desired power level. For less than 75 hp nitrous jetting, premium fuel (92 R/M Octane or better) should be used. If using 75 hp or greater, it is recommended that you use high octane racing fuel for maximum engine safety.

ZEX #82239 Nitrous System Tune-Up Specs

| | 50 hp | 75 hp | 100 hp | 125 hp | 150 hp | 175 hp | 200 hp |
|-------------------------------|-------|-------|--------|--------|--------|--------|--------|
| Nitrous (950 psi) | | | | | | | |
| Nozzle Jet | 26 | 26 | 26 | 54 | 54 | 54 | 54 |
| Distribution Block Jet | 32 | 43 | 57 | 56 | 67 | 76 | 105 |
| Fuel (40 psi) | | | | | | | |
| Nozzle Jet | 19 | 19 | 19 | 19 | 19 | 19 | 19 |
| Distribution Block Jet | 19 | 21 | 24 | 28 | 33 | 38 | 46 |
| Ignition Retard (deg.) | 2 | 3 | 4 | 5 | 6 | 7 | 8 |

Wiring Diagram

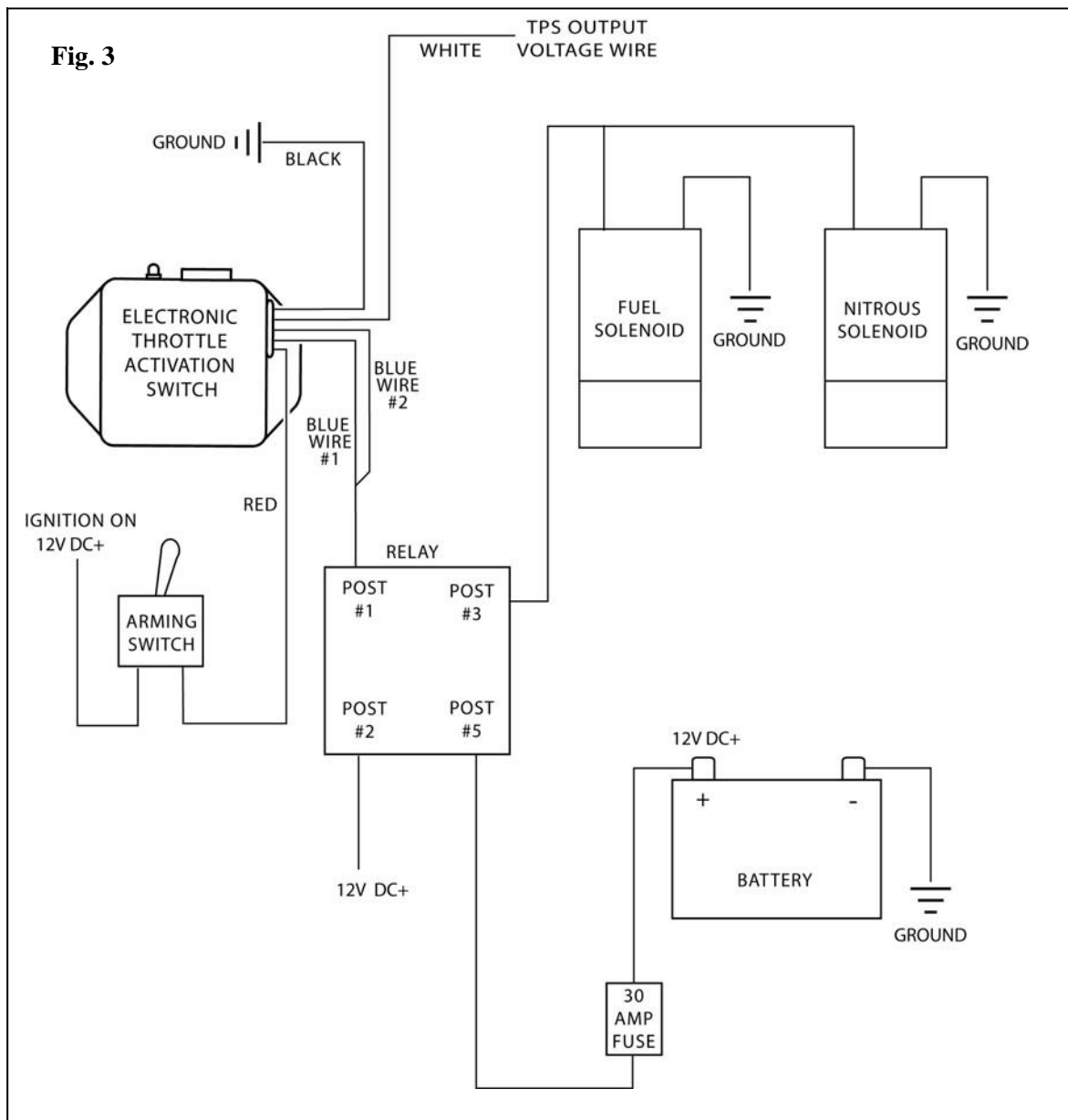

Limited Warranty

ZEX™ warrants that all of its products are free from defects in material and workmanship, and against excessive wear for a period of (1) one year from the date of purchase. This **limited warranty** shall cover the original purchaser.

ZEX's obligation under this warranty is limited to the repair or replacement of its product. To make a warranty claim, the part must be returned within (1) one year of purchase to the address listed below, freight prepaid. Items covered under warranty will be returned to you freight collect.

It is the responsibility of the installer to ensure that all of the components are correct before installation. We assume no liability for any errors made in tolerances, component selection, or installation.

There is absolutely no warranty on the following:

- A) Any parts used in racing applications;**
- B) Any product that has been physically altered, improperly installed or maintained;**
- C) Any product used in improper applications, abused, or not used in conjunction with the proper parts.**

There are no implied warranties of merchantability or fitness for a particular purpose. There are no warranties, which extend beyond the description of the face hereof. ZEX™ will not be responsible for incidental and consequential damages, property damage or personal injury damages to the extent permitted by law. Where required by law, implied warranties or merchantability and fitness are limited for a term of (1) one year from the date of original purchase.

This warranty gives you specific legal rights and you may also have other legal rights, which vary from state to state.