



Installation Instructions

EFI Sportbike Dry Nitrous System (82080)

Thank you for choosing ZEX™. If at any time you have questions regarding this or any of our products, please call our ZEXTEK™ support line at 1-888-817-1008.

Read this installation manual completely before attempting to install your nitrous system. Failure to do so may result in damage to your engine or bike and/or physical harm to yourself. ZEX™ is not responsible for damage or injuries caused by improper use of this nitrous kit.



Kit Parts List

<u>DESCRIPTION</u>	<u>QTY.</u>	<u>DESCRIPTION</u>	<u>QTY.</u>
Nitrous Solenoid	1	.036 Nitrous Jet	1
Solenoid Bracket	1	Arming Switch	1
-3AN to 1/8NPT Fitting	1	Aircraft Switch Cover	1
-4ANto ¼ NPT Filter Fitting	1	Red 18 GA. Wire	6ft.
1/8 to ¼ NPT fitting	1	White 18 GA. Wire	6ft.
24" Hose, -3AN, purple	1	Solenoid Screws	2
3' Hose, -4AN, purple	1	#14 Bracket Screws	2
Nitrous Nozzle	1	5/16-18 X 1" Bolt for Bottle Brackets	2
2lb. Polished Nitrous Bottle w/Valve	1	5/16 - 18 Nut for Bottle Brackets	2
Bottle Bracket	1	5/16 Flat Washer	2
Bottle Siphon Tube	1	Electronic TPS Switch	1
Siphon Tube Compression Fitting	1	15 Amp Fuse	1
.028 Nitrous Jet	1	15 Amp Fuse Holder	1
.032 Nitrous Jet	1	1/16-27 NPT Tap	1

Why our nitrous system is better

- A complete sportbike specific nitrous system. Everything is included in this kit for a safe, easy installation on EFI motorcycles.
- Adjustable from 30-60 horsepower. Safe enough for stock engines, powerful enough for track use.
- The EFI Sportbike Dry Nitrous System is activated at wide open throttle with advanced electronics that monitor your throttle position sensor (TPS); easy and safe activation.

Read This Pre-installation Guide Before Installing Kit !!!!!!!

How the ZEX™ EFI Sportbike Dry Nitrous System works: The ZEX™ 82080 nitrous oxide injection system begins with a connection to the nitrous bottle containing pressurized liquid nitrous oxide. This connection goes to the nitrous solenoid. This solenoid is normally closed, but opens when the throttle position sensor (TPS) switch senses that the nitrous system is armed and the engine is at wide-open throttle. Once this solenoid opens, the nitrous is delivered to the nitrous nozzle via a flexible delivery line. The amount of nitrous that is injected through the nozzle is adjustable by means of a metering jet installed in the nozzle itself. This metering jet allows for easy changes in horsepower settings. While the nitrous is being injected, additional fuel must be added by an aftermarket power programmer fuel controller.

Work safely: Always wear eye protection and gloves when working with lines or hoses that contain pressurized nitrous oxide or fuel. Never transport nitrous cylinders loose behind a seat or in the back of a pick-up truck. Always disconnect the GROUND side of the battery when working on any electrical components.

Nitrous oxide won't fix problems you already have: Before you install your nitrous system, be sure your engine is in good mechanical condition. Intermittent wiring problems, etc., can lead to erratic system performance and possible engine damage.

Never defeat operation of the safety relief disc in the nitrous cylinder's valve: It's required by law and is there for your safety. Never drill, machine, weld, deform, scratch, drop, or modify a nitrous oxide tank in ANY way whatsoever!

Never overfill nitrous cylinders: That little bit extra will put you and others at risk of injury. More often than not, when the cylinder warms up, the pressure goes above the limit of the safety relief disc and you lose all the nitrous you just paid for.

All the power comes from the fuel, not the nitrous: Nitrous oxide is simply a tool that allows you to adjust how much and how quickly the engine burns the fuel. If the fuel isn't there, the power won't be either.

Avoid detonation at all times: Nitrous enhanced detonation is much more damaging than detonation that occurs when naturally-aspirated due to the increased amount of fuel available for releasing energy and the fact that more oxygen is present.

When system is activated, if something doesn't feel or sound right, BACK OFF: If you hear any detonation or feel anything unusual, get off the throttle. It's a lot easier to check everything over than it is to just try to ride through it and damage expensive parts. Don't activate or have the system activated when you hit the stock rev limiter. The stock rev limiter is a fuel cutoff. If you cut fuel while you're injecting nitrous, you're instantly very lean. This momentary lean condition has the potential of causing engine damage.

Spark plugs and nitrous performance: Sometimes, factory type projected nose spark plugs will produce a detonation condition during nitrous use. The solution to the problem is to install spark plugs that have a colder heat range and proper ground strap design for nitrous use. Consult your preferred spark plug manufacturer to ensure you install the correct plugs for the nitrous level you choose to run. Also, due to the cooler and denser inlet air charge that nitrous creates, it may be necessary to close-up your spark plug gaps to eliminate any misfiring. In our experience, tightening up your plug gap .003 to .005 in. will help to ensure proper ignition. You may be able to run a wider gap, or you may have to close them up, just be aware of this if you start to experience an ignition misfire when you are using your nitrous system.

Do not use Teflon sealing tape on any fittings in a ZEX™ Nitrous System: It is easy for Teflon tape to get pulled into the system, causing blockages that can ultimately lead to incorrect nitrous system performance and potentially, engine damage. Only use liquid thread sealer for all NPT type fittings. Do not use any thread sealing compound on AN style threads.

Do not attempt to start your engine if nitrous has been accidentally injected into the engine while it was not running: If this occurs, disable the ignition, then open the throttle to wide-open. Hold the clutch in, and with the throttle wide open, engage the starter and turn over the engine for several seconds to clear the nitrous from the engine. Failure to do this before attempting to restart the engine can lead to a dangerous intake system backfire.

When finished using your nitrous system, close the nitrous bottle valve and relieve the line pressure: This eliminates the possibility that nitrous could inadvertently accumulate in the intake system while the nitrous system is not being used.

Do not run excessive bottle pressures: Excessive bottle pressures, over 1100 psi, are dangerous to your engine. Your ZEX™ nitrous system is calibrated and optimized to operate from 900-1000 psi. Exceeding this will not improve performance. Over 1100 psi also runs the danger of locking the nitrous solenoid closed due to

excessive pressure working against the valve's plunger. If this happens, you must cool the nitrous bottle down to lower the pressure. This will allow the valve to operate properly again.

Start with the lowest horsepower setting and work your way up: This ensures if you have any tuning issues to work out on your bike, they will get sorted out with a smaller shot of nitrous that will be less likely to damage your engine. Once you have the bike working well on the smaller shot, you can then safely start to step up your nitrous kit horsepower.

How to adjust power levels: The ZEX™ EFI Sportbike Dry Nitrous System is designed for multiple power levels. Metering jets installed in the nitrous nozzle control these power levels. To change the power output, all you need to do is install the appropriate jet and add additional fuel with your power programmer.

Installation Instructions

Step 1: Decide where to put everything

Before you start to install the various components of this kit, you'll have to find the best locations of each component by trial fitment and careful measurement. First, decide where you want to mount the nitrous solenoid. Remember, the stainless steel braided line that connects the nitrous solenoid to the nitrous nozzle is 24 inches long. Observe and mark the location on one of the air inlet tubes where you would like to put the nitrous nozzle. The arming switch should be installed in a position convenient to the rider, but not in an area where it could be accidentally armed. Next, decide where and how you'll mount the nitrous supply bottle. The bottle comes without a siphon tube installed, so in that configuration, it needs to be mounted upside down. If you want the bottle mounted vertically, you will have to unscrew the bottle valve and install the included compression fitting and siphon tube. Finally, have a reputable performance shop fill your nitrous bottle before you begin. Do not overfill the nitrous bottle.

Step 2: Mount Nitrous Supply Bottle

There are two different positions you can mount the bottle in. The first position is to mount the bottle "upside-down". This is the correct position for the bottle as it comes in the kit, as the bottle does not have a siphon tube installed from the factory. If you would like to install the bottle in the "vertical" position, you will have to remove the bottle valve and install the compression fitting and siphon tube that is included in the kit. Remember to re-torque the bottle valve to 60 ft.lbs. Remember to always mount the bottle so that as your bike accelerates, the liquid flows towards the pick-up. Attach the 3 ft. delivery line to the bottle outlet.

Step 3: Run the Nitrous Delivery Line

Attach the -4AN delivery line to the bottle and route it through the bike while using the supplied cable ties to secure it in place.

Step 4: Mount Nitrous Solenoid:

Install the -4AN filter fitting into the inlet and the -3AN fitting into the outlet of the nitrous solenoid. Keeping in mind the length restrictions of the nitrous nozzle feed line, mount the nitrous solenoid and connect the -4AN feed line to the solenoid inlet. Connect the 2ft. long -3AN nozzle line to the solenoid outlet fitting.

Step 5: Install Nitrous Nozzle

Optimum nozzle placement is 1" to 8" from the air box plenum. Locate the nozzle in one of the two air inlet tubes. After you have determined where to mount the nitrous nozzle in the air intake, make sure this location won't interfere with other components. After you've found the spot, mark it and drill a 1/4 (.250)-inch mounting hole and tap the hole with the included 1/16 NPT tap. Once the nozzle is installed, place the appropriate tuning jet in the nozzle and attach the 3-foot long, -3AN hose to the nozzle (Fig. 1).

Step 6: Wire It

Once you have mounted the components, you are ready to wire the nitrous system. Refer to the wiring diagram for the correct connections (Fig. 2). Remember to combine both blue wires together for proper system activation.

Step 7: Program Activation Switch

Now that you have completed the wiring of your nitrous system, the next step is to program the Activation Switch. To program the Activation Switch, turn the motorcycle's ignition on, but do not start the engine. Turn the nitrous arming switch to the "ON" position. Go to the Electronic Throttle Position Switch (ETPS) and locate the push-button switch. Depress, then release, the push-button switch. Observe the ETPS's Operation Light. At this point, it should be RED. This RED light informs you that the ETPS's Activation Switch is in learn mode. Return to the throttle and open it all the way, holding it there for ten seconds. Release the throttle and go back to the ETPS and observe the Operation Light. At this point, the light should be flashing continuously from RED to GREEN to OFF. This is the ETPS's way of telling you that it has successfully learned the voltage curve of your engine's throttle position sensor. Go back to the system's arming switch and turn it off, then turn it back on. Go back to the ETPS and observe the Operation Light. It should be solid GREEN at this point. This informs you that the system is armed and ready to activate at wide-open throttle. Return to the throttle and open it all the way, several times. You should hear the solenoid click each time you reach wide-open throttle. At this point, your Activation Switch is fully programmed and ready for use. If you ever transfer your nitrous system to another motorcycle, perform this same procedure to "relearn" the ETPS Activation Switch.

Step 8: Adjust Fuel Delivery

Using an aftermarket power programmer, add additional fuel in the RPM ranges you plan on spraying your nitrous system. It is critical that this fuel is added, spraying nitrous into an engine without adding additional fuel will cause a severe lean condition. A lean condition can lead to detonation and severe engine damage. It is best to tune your engine to achieve a 11.5 - 12.0 to 1 air fuel ratio when using nitrous. We recommend the FAST™ air-fuel meter (part #170501) for sportbike applications. This meter will measure your air-fuel ratio and give you, or your tuner, the information needed to make the correct fuel adjustments. Visit www.fuelairspark.com or call our tech line at 800-999-0853 for more information.

Step 9: Final Inspection

1. Perform a final inspection of all plumbing and electrical connections to ensure that they are correct.
2. Open the nitrous bottle valve. Listen carefully for any leaks as your valve is opened. Leaks in the nitrous supply line will be obvious because they will be covered in frost.
3. If everything checks out, close the nitrous bottle and relieve the line pressure.

Step 7: Check Fuel Quality & Ignition Timing

The last thing to do before enjoying your new nitrous system is to ensure that premium fuel (92 R/M Octane or better) is in the fuel tank and that your ignition timing is set correctly. It is recommended that you use the stock ignition timing and not advance it when using nitrous. If the correct ignition timing is not used, severe engine damage may occur from detonation.

Step 8: Enjoy!

After everything has been checked over and properly set-up, turn on the nitrous bottle and enjoy your ZEX™ EFI Sportbike Dry Nitrous System.

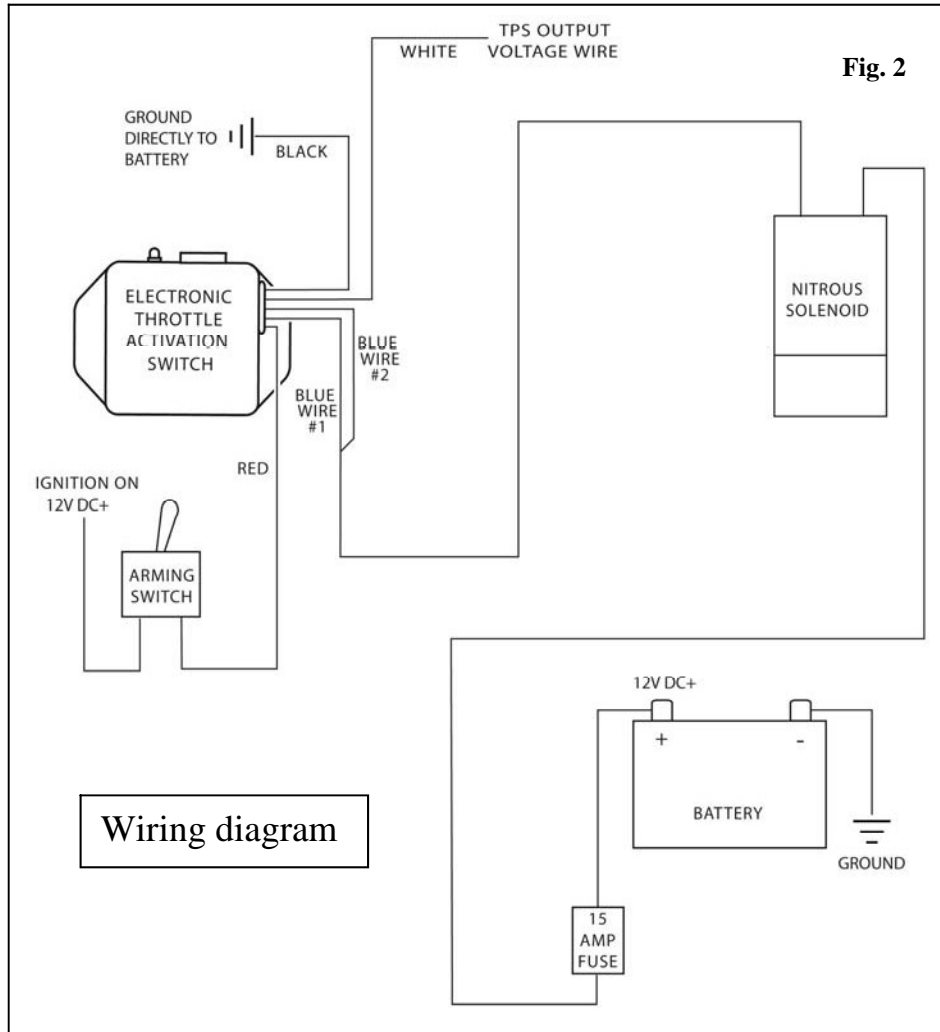
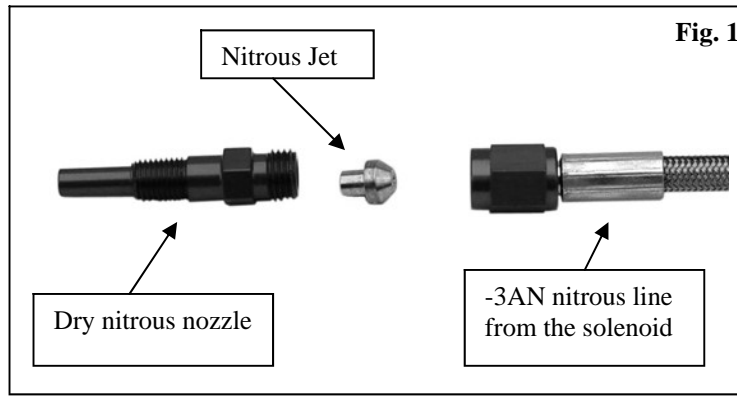

ZEX™ #82080 Nitrous System Tune-Up Specs

	30hp	45hp	60hp
Nitrous Jet (900psi)	28	32	36



3406 Democrat Road
 Memphis, TN, 38118
 1-888-817-1008
 WWW.ZEX.COM