



Installation Instructions

4 Cyl. Direct Port Nitrous System (82030)

Thank you for choosing ZEX. If at any time you have questions regarding this or any of our products, please call our ZEXTEK support line at 1-888-817-1008.

Read this installation manual completely before attempting to install your nitrous system. Failure to do so may result in damage to your engine or vehicle and/or physical harm to yourself. ZEX is not responsible for damage or injuries caused by improper use of this nitrous kit.



Kit Parts List

<u>DESCRIPTION</u>	<u>QTY.</u>	<u>DESCRIPTION</u>	<u>QTY.</u>
Nitrous Solenoid	1	.038 N20/ Fuel Jet	1
Fuel Solenoid	1	.043 N20/ Fuel Jet	1
7.5" Hose, -3AN, red, .040 ID	4	.046 N20/ Fuel Jet	1
7.5" Hose, -3AN, purple, .086 ID	4	.054 N20/ Fuel Jet	4
24" Hose, -3AN, red, .086 ID	1	.056 N20/ Fuel Jet	1
24" Hose, -3AN, purple, .106 ID	1	.057 N20/ Fuel Jet	1
3' Hose, -4AN, purple	1	.067 N20/ Fuel Jet	1
16' Hose, -4AN, purple	1	.076 N20/ Fuel Jet	1
Direct Port Nitrous Nozzles	4	.105 N20/ Fuel Jet	1
Distribution Block "A"	1	Arming Switch	1
Distribution Block "B"	1	Throttle Activation Switch	1
Distribution Block Jet Fitting	2	Red 18 GA. Wire	15ft.
¼ NPT to -4 AN Filter Fitting	2	Red 14 GA. Wire	15ft.
-3 AN to 1/8 NPT Fitting	2	30amp Fuse Holder	1
-4 AN to 1/8 NPT Fitting	1	30amp Fuse	1
10lb. Nitrous Bottle w/Valve	1	Bosch 20amp Mini Relay	1
Bottle Bracket (short)	1	5/16-18 X 1" Bolt for Bottle Brackets	4
Bottle Bracket (long)	1	5/16 - 18 Nut for Bottle Brackets	4
Throttle Switch/Solenoid Bracket	3	5/16 Flat Washer	4
.019 N20/Fuel Jet	5	Solenoid Bracket Screws	4
.021 N20/ Fuel Jet	4	4-40 X 5/8 Socket Head Cap Screw	2
.024 N20/ Fuel Jet	1	4-40 Nylon Insert Lock-Nut	2
.026 N20/ Fuel Jet	5	8-32 x 1/2in. Socket Cap Screw	2
.028 N20/ Fuel Jet	1	1/8-27 NPT Tap	1
.032 N20/ Fuel Jet	1	Schrader Valve Removal Tool	1
.033 N20/ Fuel Jet	1		

Why our nitrous system is better

- A complete "Direct Port" nitrous system. Everything is included in this kit for a safe, proper installation.
- Adjustable from 50-200 horsepower. Safe enough for stock engines, powerful enough for racing use.
- Uses one injector nozzle per cylinder. Gives perfect nitrous and fuel distribution.
- Features easy to install, pre-made nozzle flex-lines. No hours wasted on cutting and bending distribution hard-lines.
- Dual-stage jet technology uses one jet in the distribution block and one jet in the injector nozzle. Offers much finer tuning adjustments as well as easy HP level changes.

- Dual-stage jet technology gives separate tune-ups for both speed-density and mass-air equipped vehicles. Other kits on the market ignore the differences in these two engine operating systems.
- Unique nozzle design has “Active Fuel Control” built in. This feature monitors bottle pressure and when the nitrous system is engaged, it adds or subtracts enrichment fuel so the engine never runs too rich or too lean.

Quick Start Reference Guide

How the ZEX 4 Cyl. Direct Port Nitrous System works: The ZEX 82030 nitrous system begins with a connection to a supply cylinder containing pressurized liquid nitrous oxide and a connection to the engine’s fuel system. These connections go to the system’s nitrous and fuel solenoids, respectively. These solenoids are normally closed, but are opened when the nitrous system is armed, and the throttle switch is activated by going to wide-open throttle. Once these solenoids open, the nitrous and fuel are delivered to the nozzles, via braided stainless steel delivery lines. The amount of nitrous and fuel that is injected is adjustable by means of metering jets installed in the distribution blocks and the nozzles. These metering jets allow for easy changes in horsepower settings.

Work Safely: Always wear eye protection and gloves when working with lines or hoses that contain pressurized nitrous oxide or fuel. Never transport nitrous cylinders loose in a trunk or the back of a pick-up truck and especially NOT within a vehicle’s interior whether the cylinder is full OR empty. Always disconnect the GROUND side of the battery when working on any electrical components.

Nitrous Oxide won't fix problems you already have: Before you install your nitrous system, be sure your engine is in good mechanical condition. Intermittent wiring problems, etc., can lead to erratic system performance and possible engine damage.

Never defeat operation of the safety relief disc in the nitrous cylinder's valve: It's required by law and is there for your safety. Never drill, machine, weld, deform, scratch, drop, or modify a nitrous oxide tank in ANY way whatsoever!

Never overfill nitrous cylinders: That little bit extra will put you and others at risk of injury. More often than not, when the cylinder warms up, the pressure goes above the limit of the safety relief disc and you lose all the nitrous you just paid for.

All the power comes from the fuel, not the nitrous: Nitrous oxide is simply a tool that allows you to adjust how much and how quickly the engine burns the fuel. If the fuel isn't there, the power won't be either.

Avoid detonation at all times: Nitrous enhanced detonation is much more damaging than detonation that occurs when naturally-aspirated due to the increased amount of fuel available for releasing energy and the fact that more oxygen is present.

When system is activated, if something doesn't feel or sound right, BACK OFF: If you hear any detonation or feel anything unusual, get off the throttle. It's a lot easier to check everything over than it is to just try to drive through it and damage expensive parts. Don't activate or have the system activated when you hit the stock rev limiter. The stock rev limiter is a fuel cutoff. If you cut fuel while you're injecting nitrous, you're instantly very lean. This momentary lean condition has the potential of causing engine damage.

Spark plugs and nitrous performance: Quite often, factory type, wide-gap, projected nose spark plugs will produce a detonation condition after a few seconds of nitrous use. The solution to the problem is to install spark plugs that have a colder heat range and proper ground strap design for nitrous use. Consult your preferred spark plug manufacturer to ensure you install the correct plugs for the nitrous level you choose to run.

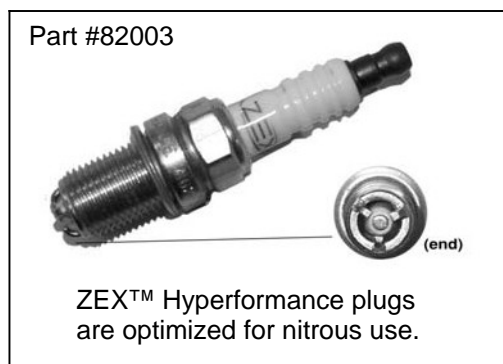

Reading Plugs & Tuning ZEX Nitrous Kit: If you've installed larger injectors or have otherwise increased the capacity of your fuel system, you need to read the following. Because the real limit of how much power you make with the ZEX™ Nitrous Kit is your car's fuel system, you need to tune up to that limit. Start with the lowest power level nitrous jet and corresponding fuel metering jet. Make a full throttle pass at the drag strip and read the plugs. Not enough nitrous/too much fuel results in a sooty, black plug coloration. This coloration means that the fuel mixture is too rich. Too much nitrous will exhibit high heat in the form of a bluish or rainbow-like coloring on the plug's metal surfaces. This means your engine is about to, or is, detonating. If this is observed, ensure the proper spark plugs are installed, reduce nitrous/increase fuel delivery, and ensure the proper grade of fuel is being used. When you check the spark plugs, check EVERY plug. Don't just spot check the easiest plug you can access. Due to the wide possibility of air/fuel mixture variations, you need to check every single plug for signs of detonation or other problems. If your plugs indicate too much fuel, trim the fuel delivery down by installing smaller metering jets. If you are too lean/not enough fuel, you need to install a larger metering jet to increase fuel delivery.

Clear Nitrous Lines After Use: Close bottle valve. Use purge kit to relieve line pressure or open line fitting to let nitrous bleed off.

Do not use Teflon sealing tape on any fittings in a ZEX Nitrous System: It is easy for Teflon tape to get pulled into the system, causing blockages that can ultimately lead to incorrect nitrous system performance and potentially, engine damage. Only use liquid thread sealer for all NPT type fittings. Do not use any thread sealing compound on AN style threads.

Do not attempt to start your engine if nitrous has been accidentally injected into the engine while it was not running: Disable the ignition and, with the throttle wide open, turn over the engine for several seconds to clear the nitrous from the engine. Failure to do this before restarting the engine can lead to a dangerous intake system backfire.

Do not engage your nitrous system below 2500 rpm: This ensures that you will not have excessive cylinder pressures that could cause engine damage.

When finished using your nitrous system, close the nitrous bottle valve and relieve the line pressure: This eliminates the possibility that nitrous could inadvertently accumulate in the intake manifold while the nitrous system is not being used.

Do Not Run Excessive Bottle Pressures: Excessive bottle pressures, over 1100 psi, are dangerous to your engine. Your ZEX nitrous system is calibrated and optimized to operate from 900-1000 psi. Exceeding this will not improve performance. Over 1100 psi also runs the danger of locking the nitrous solenoid closed due to excessive pressure working against the valve's plunger. If this happens, you must cool the nitrous bottle down to lower the pressure. This will allow the valve to operate properly again.

Start with the lowest horsepower setting and work your way up: This ensures if you have any tuning issues to work out on your vehicle, they will get sorted out with a smaller shot of nitrous that will be less likely to damage your engine. Once you have the car working well on the smaller shot, you can then safely start to step up your nitrous kit horsepower.

Make sure your vehicle has an adequate fuel supply: Nitrous systems put a large demand on your vehicle's fuel system. Make sure you have a large enough fuel pump to handle the demands of your engine, as well as the nitrous system.

How to adjust power levels: The ZEX 4 Cylinder Direct Port Nitrous System is designed for multiple power levels. Metering jets installed in the nitrous injectors and distribution blocks control these power levels. To change the power output, all you need to do is install the appropriate set of jets. The ZEX direct port system uses a unique dual stage jetting system. There is a jet in the distribution block that adjusts the power levels and a second jet in each of the nitrous nozzles that allows the tuner to further trim nitrous and fuel for individual cylinders. The correct combination of jets is listed on the tune-up sheet on the back of this instruction manual.

Installation Instructions

Step 1: Decide where to put everything

Before you start to install the various components of this kit, you'll have to locate the best locations of each component by trial fitment and careful measurement. First, decide where you want to mount the nitrous and fuel solenoids. Remember, the stainless steel braided lines that connect these to the distribution blocks are 24 inches long. Observe and mark the location on each intake runner where you will drill and tap for the nitrous nozzles. You'll also have to decide where to install the arming switch and the nitrous bottle. The arming switch should be installed in a position convenient to the driver, but not in an area where it could be accidentally armed. To help you decide where and how you'll mount the nitrous supply bottle, check fig. 1, 2, 3, and 4 for technical restrictions on bottle mounting locations and positions. Finally, have a reputable performance shop fill your nitrous bottle with automotive grade nitrous oxide before you begin. Do not overfill the nitrous bottle.

Step 2: Mount Nitrous Supply Bottle

1. Mount the nitrous supply bottle so that it is separated from the passenger cabin.

Fastback style cars that do not have separate trunk compartments have to be equipped with a safety blowdown tube (ZEX Part # 82099). Route the tube from the safety pressure relief cap to the exterior of the car, preferably under the car. Doing so will prevent your car from filling with a cloud of nitrous oxide should the safety pressure relief cap rupture.

2. Index the pickup tube with bottle position. (Refer to fig. 1, 2, and 3). ZEX™ nitrous bottles are designed with the bottom of the siphon tube at the bottom of the bottle towards the outlet. Always mount the bottle so that as your car accelerates, the liquid flows toward the pickup tube.

Step 3: Mount Nitrous Delivery Line Under the Car

When routing the nitrous delivery line under the car, try to use the subframe as a conduit (fig.4). This protects the line and eliminates the need to use clamps. The supplied cable ties work if you can run the line higher in the under-body so that it's safe from road level obstacles such as speed bumps. For the pro-race look, you can use steel loom clamps with rubber sheathing to fasten the line to the body.

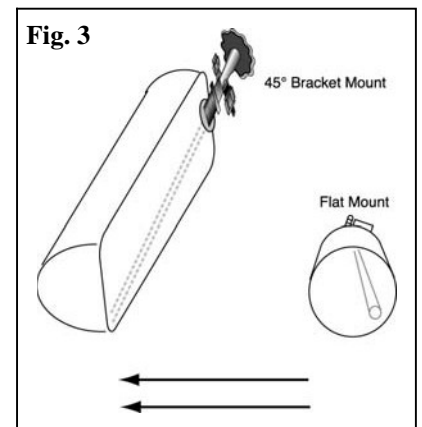
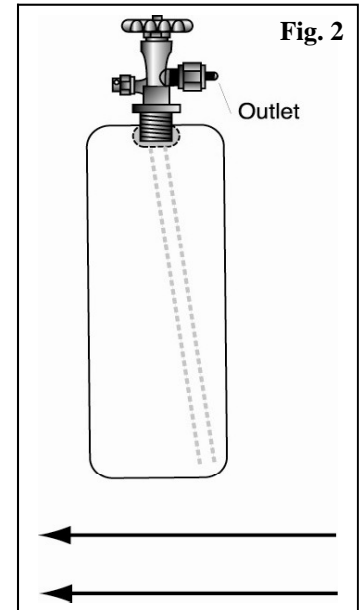
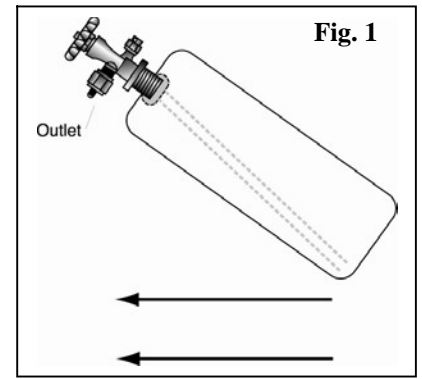

Step 4: Install Injectors and Delivery Lines

1. Remove the intake manifold. Note: It is recommended that you purchase a new intake manifold gasket for reassembly.
2. Using a 11/32 dia. drill bit, drill each intake runner where you would like to position the nitrous nozzles.
3. Use the 1/8 NPT tap that is included with the kit to tap the holes you have just drilled in the intake runners. Take special care to not tap the holes too deep. It is recommended to tap a few turns at a time, back the tap out, clean out the shavings, and test fit the nozzle to the NPT threaded hole. When all four holes have been tapped, thoroughly clean and blow out all shavings from the inside of the intake manifold.
4. Using a liquid thread locking compound on the threads, install the nozzles in the threaded holes. Make sure the nozzles are pointing in the correct direction. The outlets should face toward the cylinder head.
5. Reinstall the intake manifold, using a new intake manifold gasket.
6. Assemble the distribution blocks and lines (Fig. 5).
7. Install the jets for both fuel and nitrous in the nitrous injector nozzles (fig. 6).
8. Attach the fuel and nitrous distribution lines to the nitrous nozzles. Be sure to use a 3/8in. wrench to hold the jet fitting as you are tightening the 7/16 swivel nut on the distribution lines.
9. Assemble the -4AN inlet filter fittings and the -3AN outlet fittings into the fuel and nitrous solenoids. Make sure you use a liquid thread sealant on all NPT pipe threads. Attach the solenoid brackets to the solenoids using the pan head allen screws and find a suitable mounting location for them.

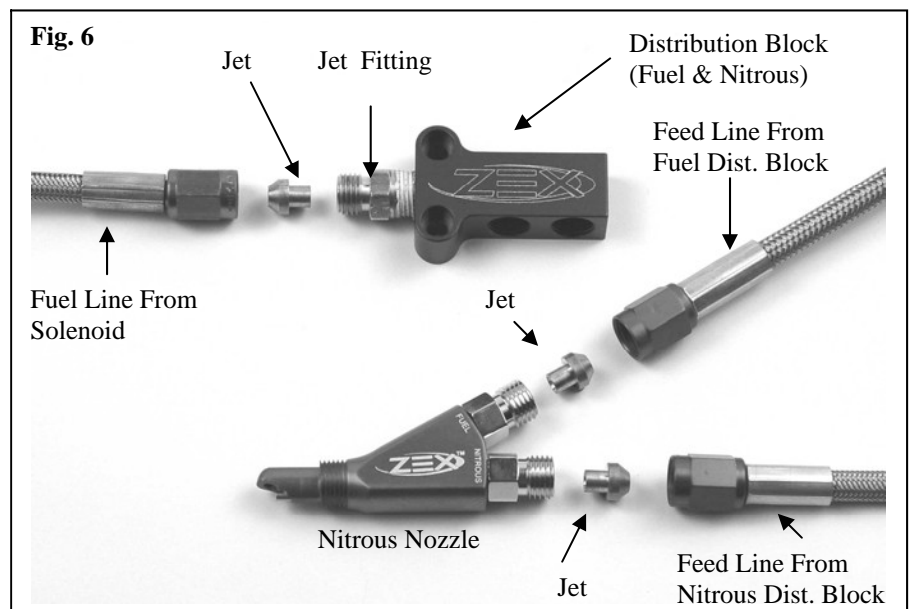
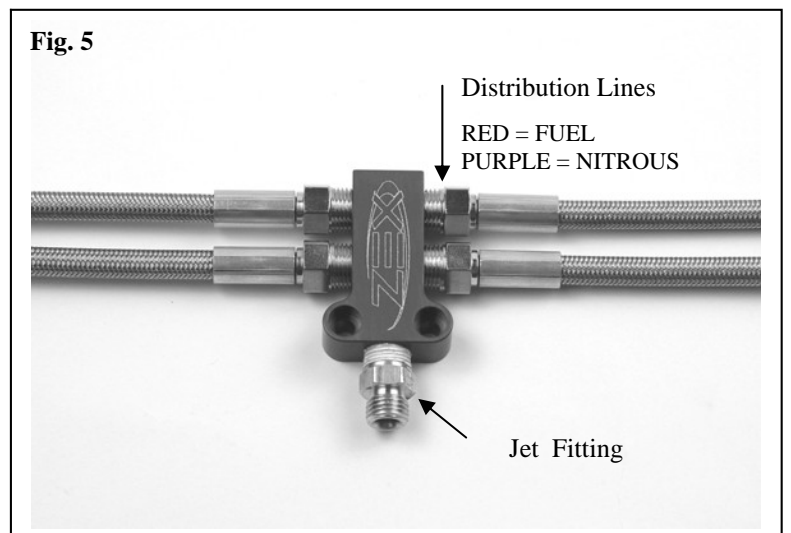
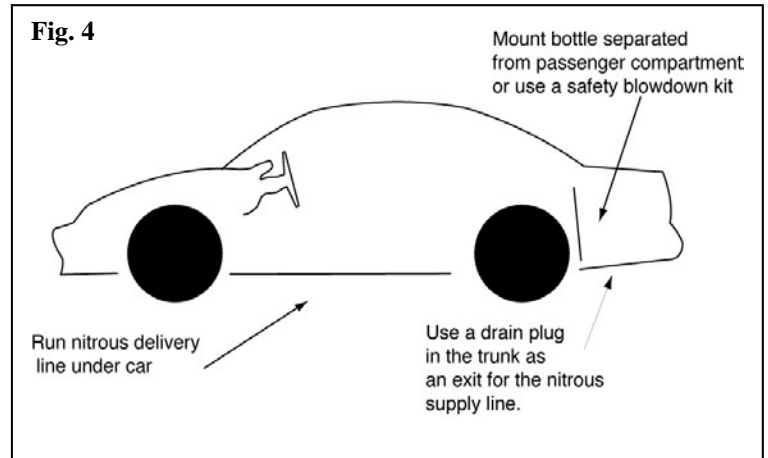

10. Insert the correct jets in the fuel and nitrous jet holders in the distribution blocks (fig. 6).

11. Attach the 24 in. -3 AN hose, with the red ends, to the fuel solenoid outlet. Attach the other end of this line to the fuel distribution block's jet fitting. Attach the 24 in. -3 AN hose, with the purple ends, to the nitrous solenoid outlet. Attach the other end of this line to the nitrous distribution block's jet fitting.

12. Attach the -4AN nitrous delivery line, from the bottle, to the nitrous solenoid inlet.

13. Provide a source of fuel from the fuel rail that will connect to the 3 ft. long -4AN hose. If needed, a -4AN to 1/8NPT fitting is supplied. Drill and tap the fuel rail for this fitting. Make sure all metal shavings are removed before reinstalling the fuel rail.

14. Attach the 3ft., -4AN fuel delivery line, from the fuel source, to the fuel solenoid inlet.

Step 5: Wiring

1. Mount the arming switch in an easily accessible area for the driver.

2. Assemble the throttle activation switch to the throttle switch bracket using the 4-40 bolts and nylon lock nuts (see Fig. 7). Do not overtighten the bolts, damage to the throttle activation switch can result.

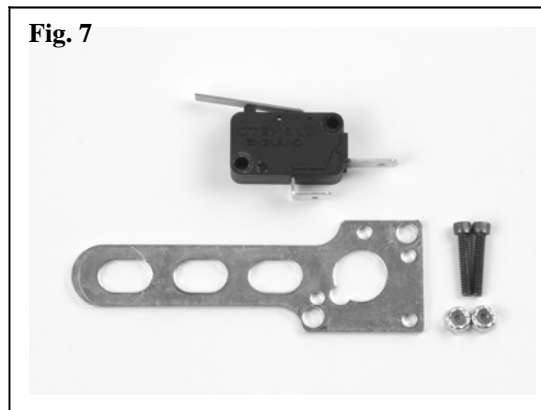

3. The throttle switch bracket is made of easily formed material. Attach the end of the bracket to one of the throttle body studs and bend the bracket in such a way as to allow the engine's throttle arm to contact and depress the switch lever at wide open throttle.

4. Using the supplied electrical connectors and wire, refer to the wiring diagram for proper routing and electrical connections for the nitrous system (see Fig. 8). Always use the supplied fuse for electrical system protection in the event of a short in the system. The best positive (+) power source for the nitrous system is a

direct connection to the battery's positive (+) post. Do not splice into the factory wire harness, it will not have the ability to supply the current required by the nitrous and fuel solenoids.

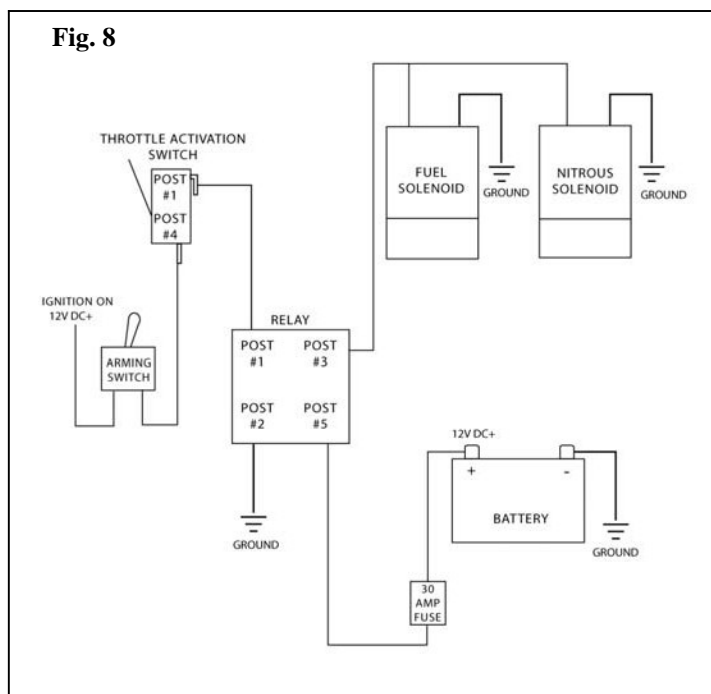

Step 6: Check Fuel and Nitrous Pressure Lines

1. Perform a final inspection of all plumbing and electrical connections to ensure that they are correct.

2. Turn the arming switch to the ON position.
3. Depress the throttle switch and listen for both solenoids to click. If they both do not click, locate the electrical problem and correct it before proceeding.
4. Start the engine and observe all fuel connections for any leaks. Fix any fuel leaks before proceeding.
5. Turn off the engine.
6. Open the nitrous bottle valve. Listen carefully for any leaks as your valve is opened. Leaks in the nitrous supply line will be obvious because they will be covered in frost.
7. If everything checks out, close the nitrous bottle and relieve the line pressure.

Step 7: Check Fuel Quality & Ignition Timing

The last thing to do before enjoying your new nitrous system is to ensure that premium fuel (92 R/M Octane or better) is in the fuel tank and that your ignition timing is set correctly. All recommended ignition timing retard amounts, on the Tune-Up Sheet, are calculated off of the base, stock ignition setting. It is important to set this with a timing gun before you use your nitrous system for the first time. Do not assume that it is set properly. If the ignition timing is not set correctly, severe engine damage may occur.

Step 8: Enjoy!

After everything has been checked over and properly set-up, turn on the nitrous bottle and enjoy your ZEX Nitrous System.

ZEX #82030 Nitrous System Tune-Up Specs

A word on why we have two different jet charts:

When nitrous is sprayed into an engine, the nitrous gas itself displaces a percentage of the air that is normally drawn into the engine. Since engines that do not use a mass-air meter (i.e. speed-density) do not look at airflow, this displaced air does not affect the amount of fuel the engine computer feeds to the engine. But, on an engine that uses a mass-air meter, the air that is displaced by injecting the nitrous, lowers the airflow seen by the mass-air meter. This causes the engine's computer to reduce the engine's fuel injector flow rate. To compensate for

this, the nitrous tune-up on a mass-air meter equipped engine is set-up to flow more fuel than an equivalent tune-up for a non mass-air meter equipped engine.

Jet chart for engines NOT using a mass-air meter (i.e. speed-density):

	50hp	75hp	100hp	125hp	150hp	175hp	200hp
Nitrous (950psi)							
Nozzle Jet	26	26	26	54	54	54	54
Distribution Block Jet	32	43	57	56	67	76	105
Fuel (40psi)							
Nozzle Jet	19	19	19	19	19	19	19
Distribution Block Jet	19	21	24	28	33	38	46
Ignition Retard (deg.)	2	4	6	8	10	12	14

Jet chart for engines using a mass-air meter:

	50hp	75hp	100hp	125hp	150hp	175hp	200hp
Nitrous (950psi)							
Nozzle Jet	26	26	26	54	54	54	54
Distribution Block Jet	32	43	57	56	67	76	105
Fuel (40psi)							
Nozzle Jet	19	19	19	19	19	21	21
Distribution Block Jet	21	26	33	43	57	57	76
Ignition Retard (deg.)	2	4	6	8	10	12	14

Normally aspirated tuning requirements:

For engines less than 10.75-1 compression ratio, using nitrous system settings of 100hp or less, pump premium fuel is required for safe operation of your ZEX Direct Port Nitrous System. For engines with 10.75-1 compression ratio or greater, using nitrous system settings higher than 100hp, high octane racing fuel is required for safe operation of your ZEX Direct Port Nitrous System. Nitrous system fuel pressure must be at least 40psi

at the inlet of the fuel solenoid. Base fuel pressures higher than 45psi may require a slight distribution block fuel jet or nozzle fuel jet adjustment to achieve optimum nitrous to fuel ratios. Track or dyno tuning will dictate this.

Forced induction tuning requirements:

For engines using 8psi or less boost, using nitrous system settings of 50hp or less, pump premium fuel is required for safe operation of your ZEX Direct Port Nitrous System. For engines using greater than 8psi of boost, using nitrous system settings higher than 50hp, high-octane racing fuel is required for safe operation of your ZEX Direct Port Nitrous System. Nitrous system fuel pressure must be at least 40psi at the inlet of the fuel solenoid. Base fuel pressures higher than 45psi may require a slight distribution block fuel jet or nozzle fuel jet adjustment to achieve optimum nitrous to fuel ratios. Track or dyno tuning will dictate this.



3406 Democrat Road

Memphis, TN 38118

ZEXTEK 1-888-817-1008